

JT400 Multivariable Transmitter Installation and Mounting “How To”

The JT400 Transmitter must be direct-mounted to an instrument manifold or secured to a pipe or wall.

Be sure that fittings and torque meet maximum pressure rating requirements.

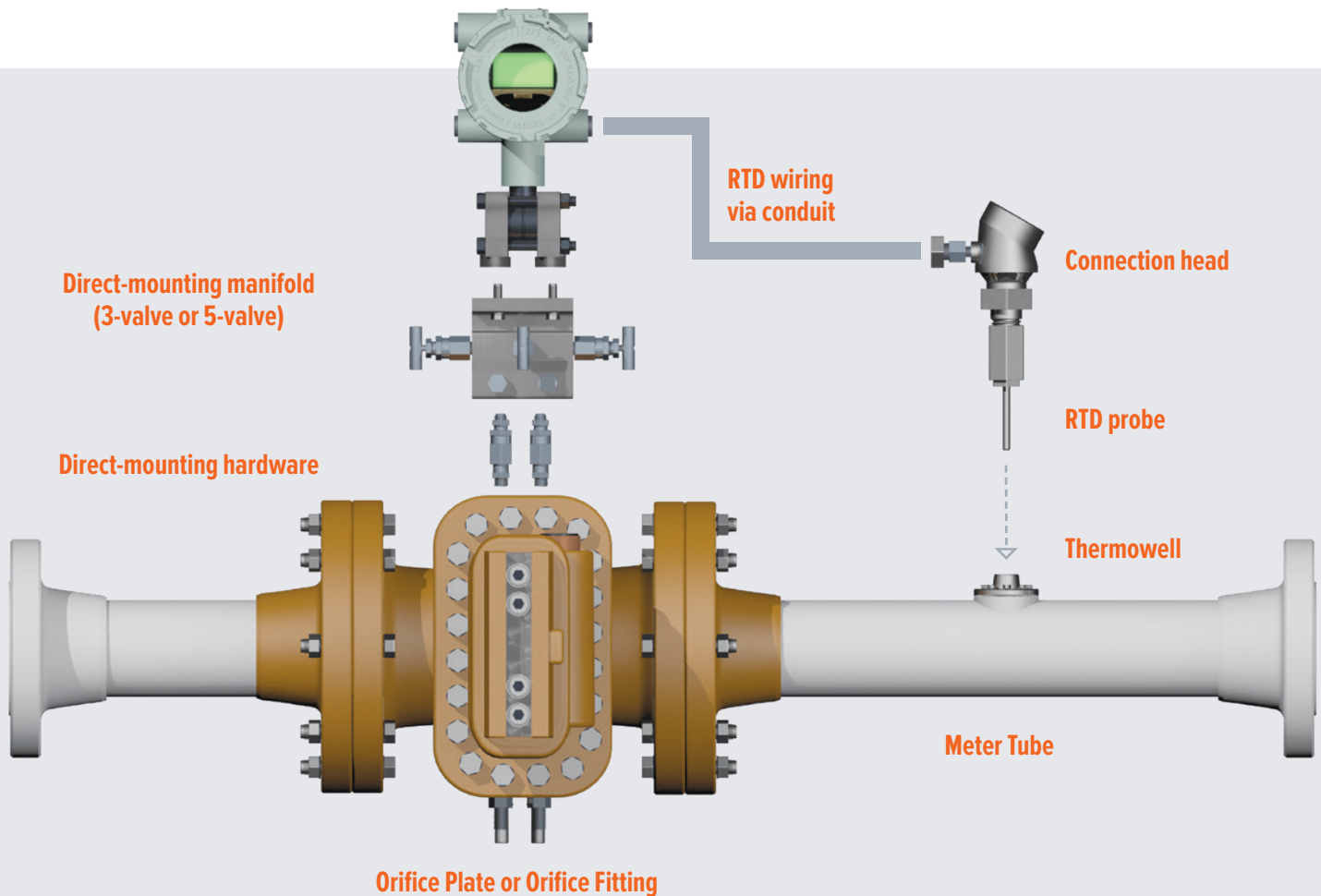

NOTE: The sensor module has an “H” stamped on the body near the flange that must be mounted on the high-pressure side of the manifold. There is an “L” stamped on the body next to the low side flange. No damage will occur if the sensor is mounted

backwards but the DP pressure reading will be reversed. The static pressure measurement is on the high side flange port.

Use short bolts to mount the unit to the manifold. Torque the bolts to 12.5 ft-lbs. Use washers if provided.

JT400 Multivariable Transmitter

Product Ratings

ELECTRICAL CONNECTIONS:

- (2) ½-in NPT Conduit fittings
- (2) ¾-in NPT Conduit fittings
- Pluggable terminal block

PROCESS CONNECTIONS:

- **DP Sensor:** Face Seal Flange with O-ring gland on 2.123-in center. Flange hold down thread: 7/16-20 (4 places). Flange ports: ¼-18 NPT female pipe 1-in deep (2).
- **SP sensors:** ½-in NPT male fitting with 1/8-in NPT female inside.

PROCESS WETTED PARTS:

- 316L Stainless steel or Hastelloy C

WETTED O-RINGS:

- Parker N0674-70 Nitrile (Buna-N) compound (2)

FLANGE BOLTS:

- 316 Stainless Steel

SENSOR FILL FLUID:

- DC200 Silicone oil 100 cs

HOUSING AND COVERS:

- Low Copper Aluminum with Polyester powder paint and yellow Chromate

PROOF PRESSURE:

- **DP Sensor:** 3000pPSI on either or both ports.
- **SP Sensor:** 3X URL

STORAGE TEMPERATURE RANGE:

- -40° C to 100°C

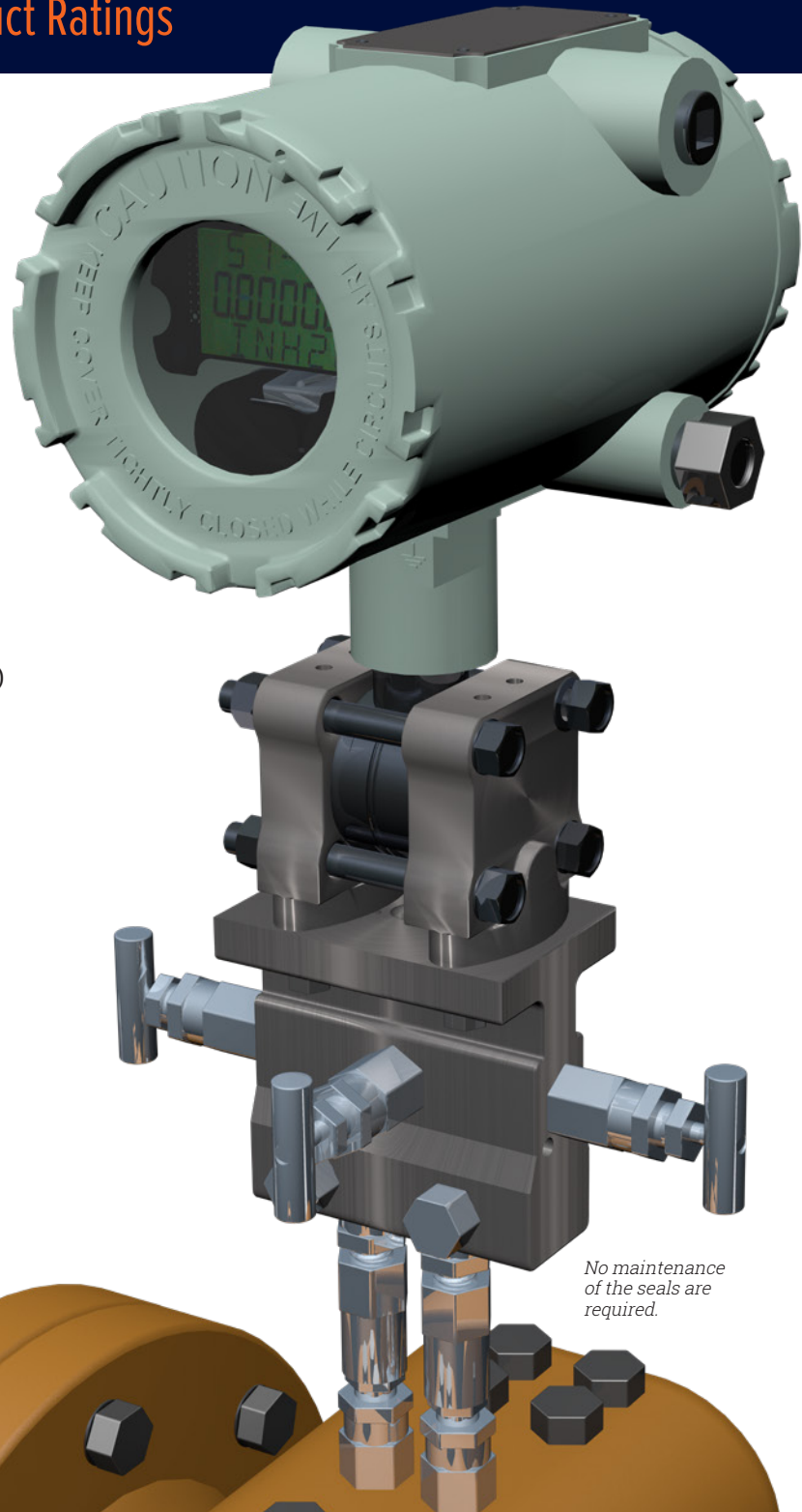

*No maintenance
of the seals are
required.*